

Kindergarten

Phonics

Week 4



Reading

Look at the picture and
circle the word.

Week 4

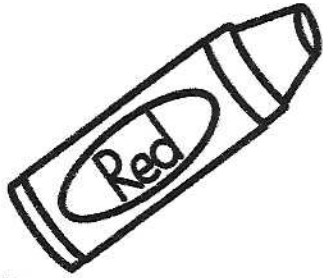

Red Bed Rat

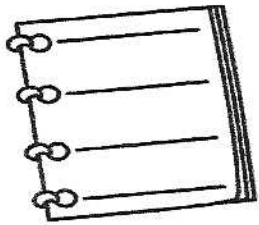

Pet Pad Sam



Men Ham Hen



Sob Cab Can

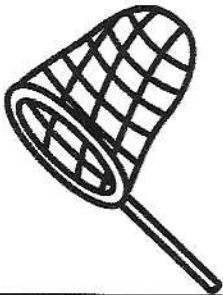

Net Not Mat

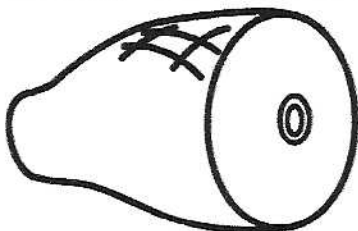





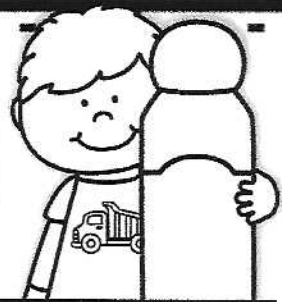

Ham Tin Hot

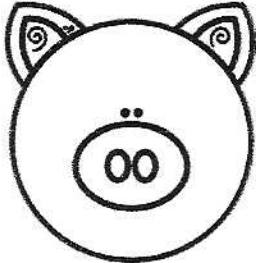
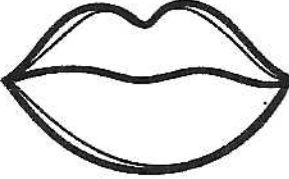
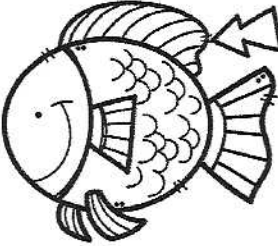
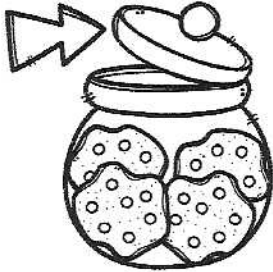
Name: _____

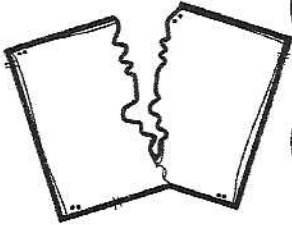

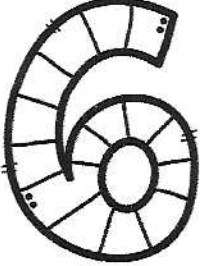
Dab a FAMILY

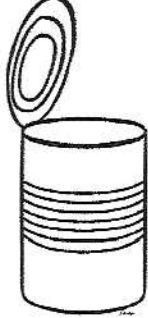
 p _ _	<p>ig</p> <p>im</p> <p>it</p>	 l _ _	<p>id</p> <p>ip</p> <p>ig</p>	 f _ _	<p>in</p> <p>it</p> <p>id</p>
 j _ _	<p>in</p> <p>ip</p> <p>id</p>	 w _ _	<p>id</p> <p>ig</p> <p>in</p>	 p _ _	<p>im</p> <p>in</p> <p>ig</p>
 r _ _	<p>ip</p> <p>id</p> <p>ig</p>	 s _ _	<p>ip</p> <p>id</p> <p>it</p>	 s _ _	<p>im</p> <p>ix</p> <p>ip</p>
 w _ _	<p>in</p> <p>im</p> <p>it</p>	 h _ _	<p>ip</p> <p>in</p> <p>it</p>	 t _ _	<p>ip</p> <p>ig</p> <p>in</p>

Name: _____

Spell & Find

Spell and find the words.

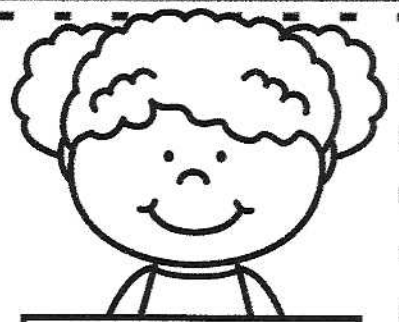

n	e	t	b	p	l
r	f	m	e	j	e
d	s	p	d	l	g
n	g	e	h	c	k
t	e	n	j	e	t

ten
leg
net
pen
bed
jet

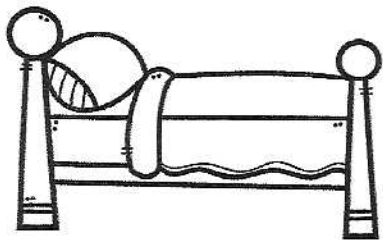

--	--	--

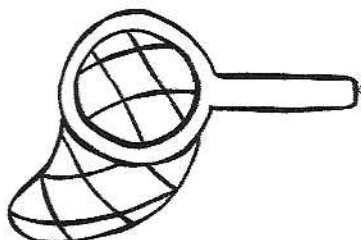

--	--	--



--	--	--

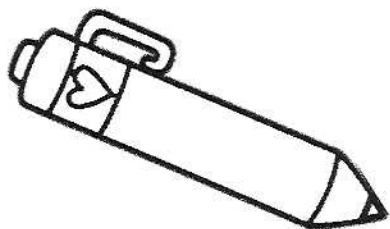

--	--	--

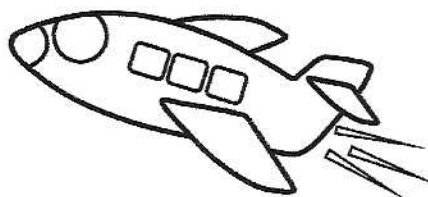

--	--	--

10

--	--	--

Phonics

Sort the pictures into the correct column.

Week 4

Rhymes with WIN

Rhymes with FOG

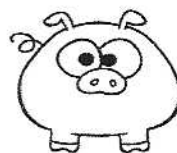
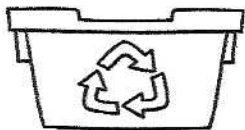

Sight Word Word Search

Directions: Using the sight word box find the words in the word search. After, write the words you found in the lines at the bottom.

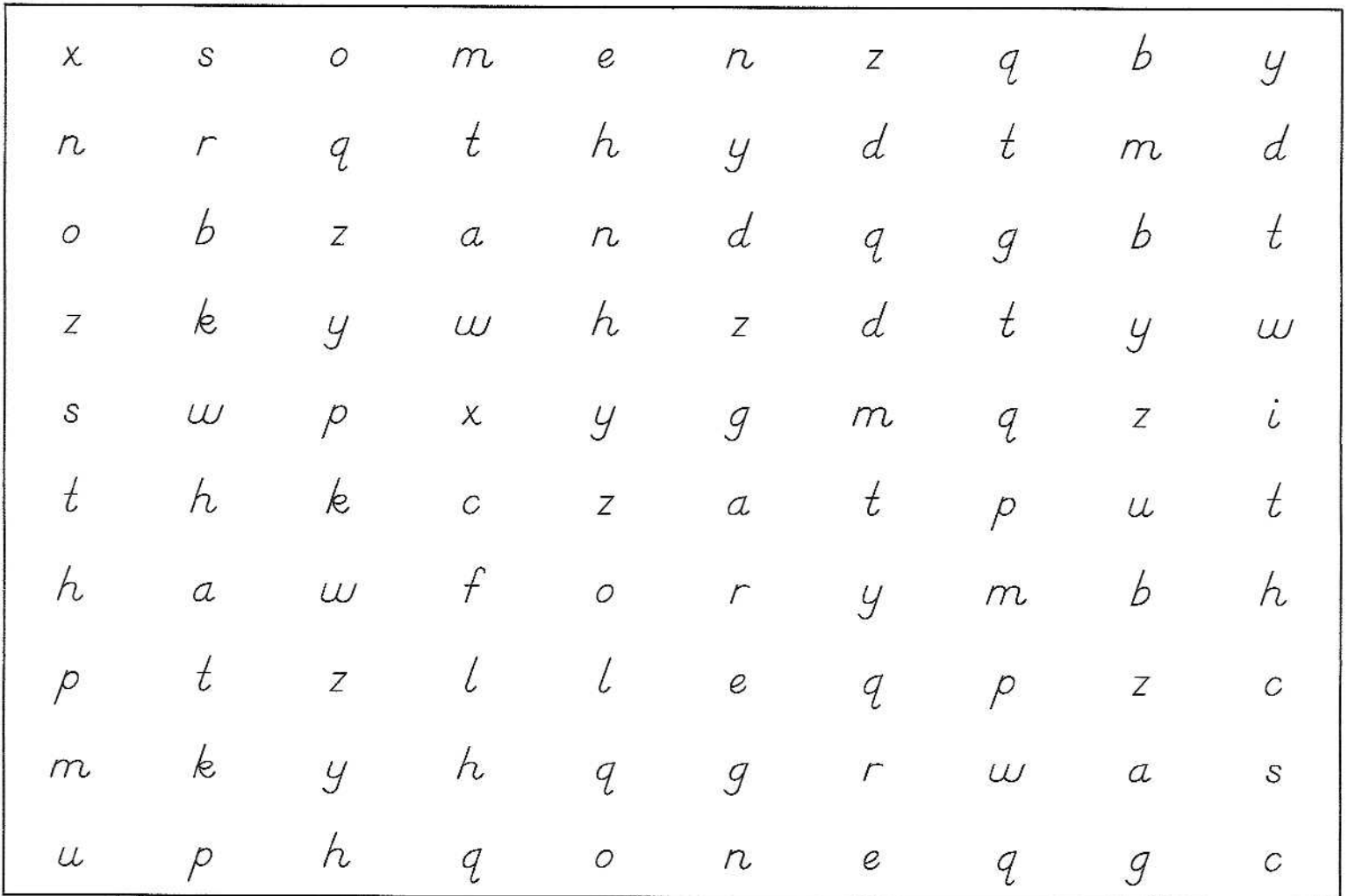

Sight Words to find:

for are no with up and
was by put some what one

Name: _____

Date: _____

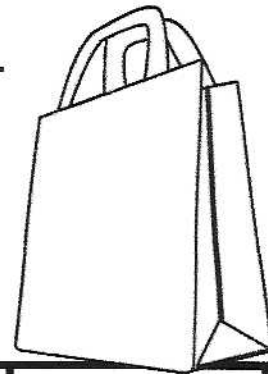

Find The Rhyming Words #7

Find the words that rhyme with "bag".

bag

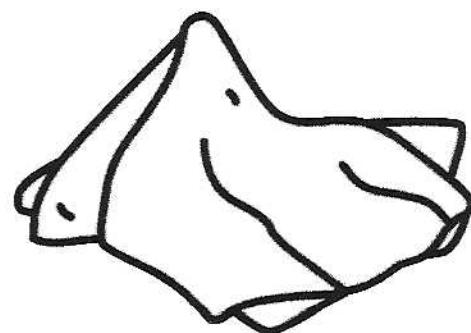
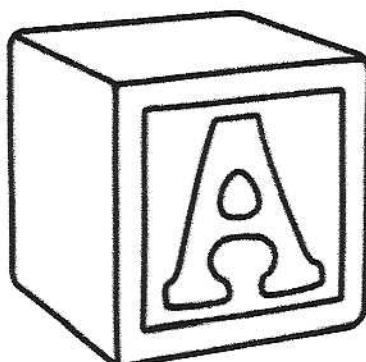
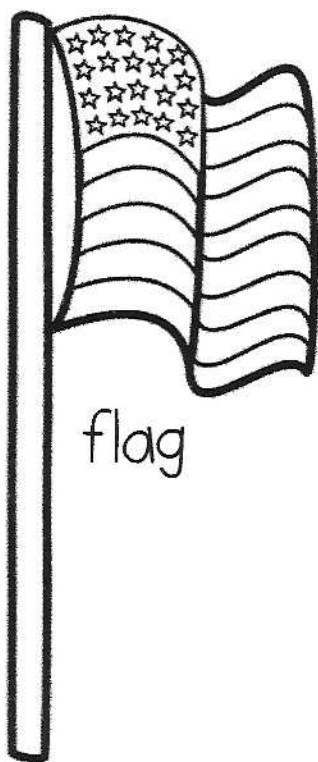
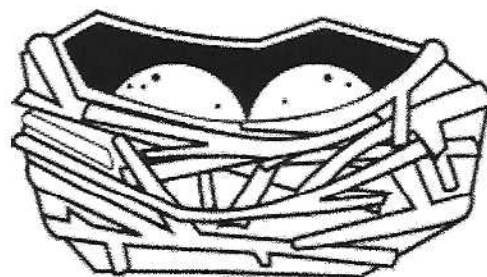
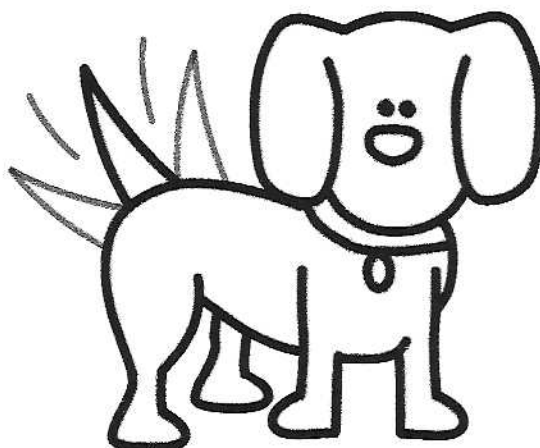
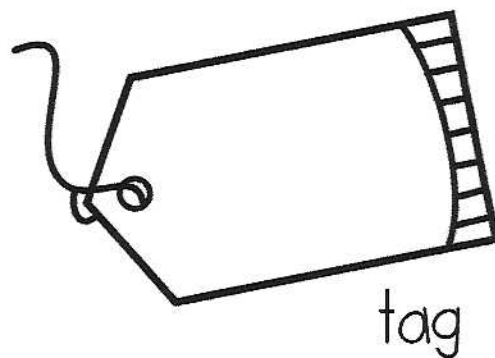
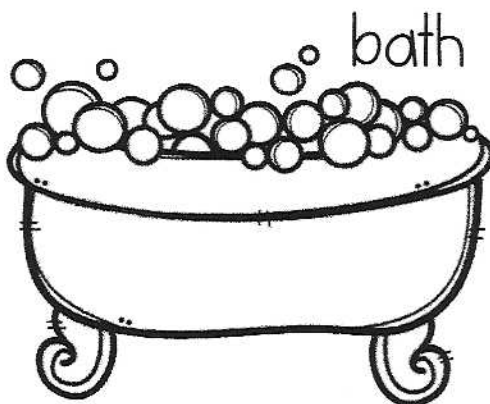
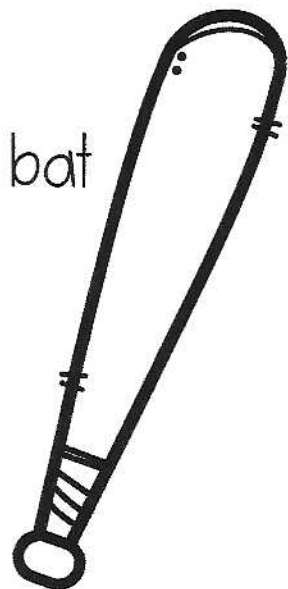

Name: _____

Date: _____

Find The Rhyming Words #8

Find the words that rhyme with "pig".

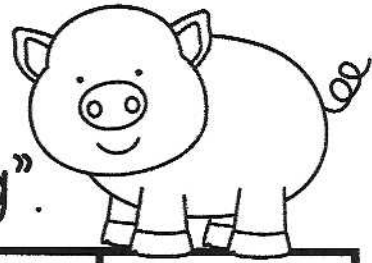

pig

big

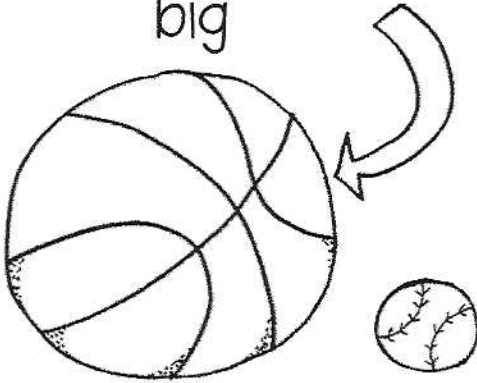

jet

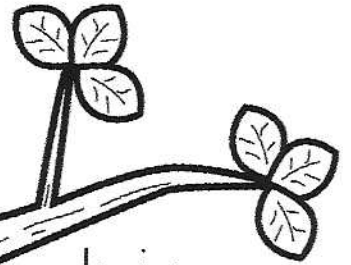

twig

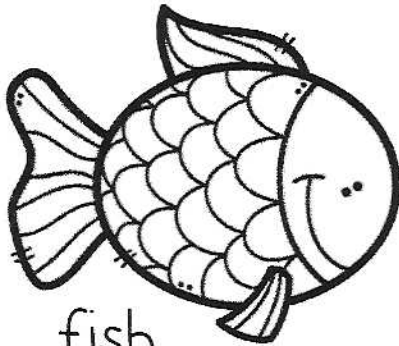

fish

dog

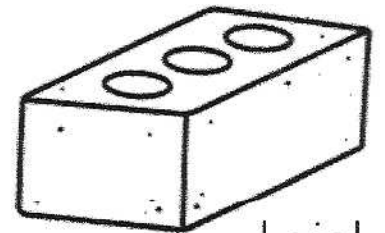

brick

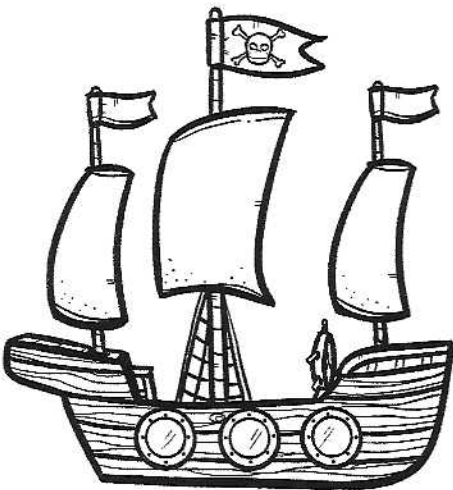

ship



wig



dig

Name: _____

Date: _____



Color The Rhyming Pictures #6

Color the rhyming pictures. Draw an 'X' through the picture that does not rhyme.

fist

fall

tall

rake

rib

cake

lid

kid

list

clip

rug

ship

hit

spin

kit

win

chin

hid

Name:

Date:

Rhyming Pairs Cut & Paste #5

Cut and paste to match the rhyming pairs.

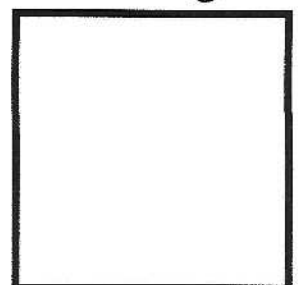
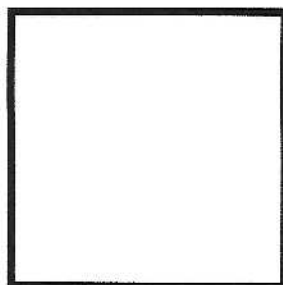
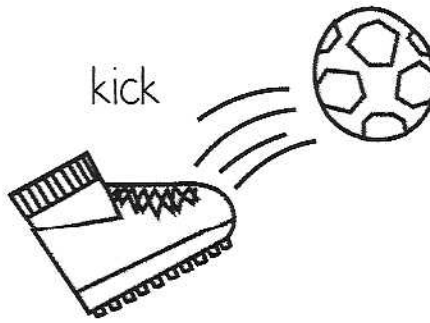
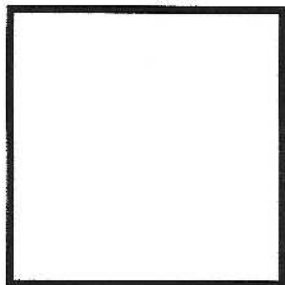
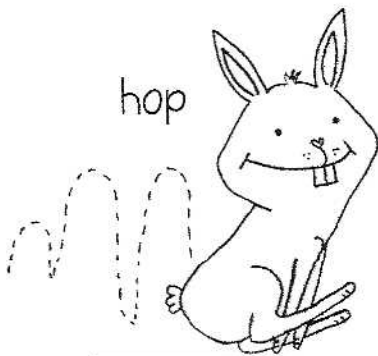
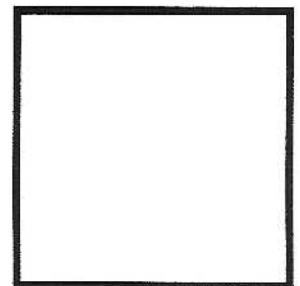
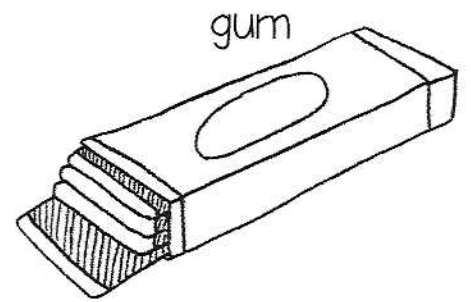
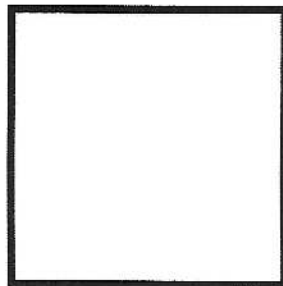
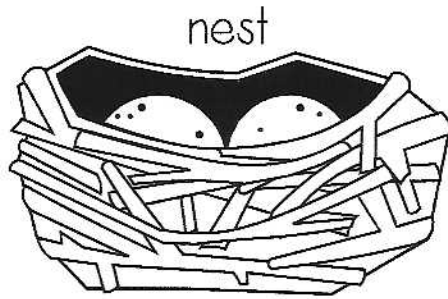
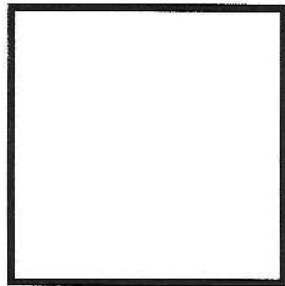
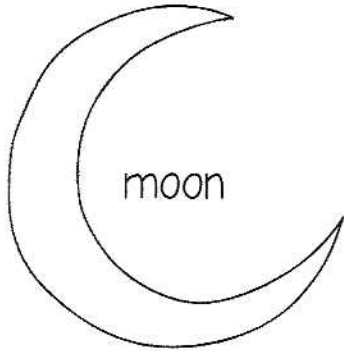

Rhyming Worksheets by Miss Vanessa



stop

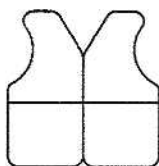

vest



spoon



drum

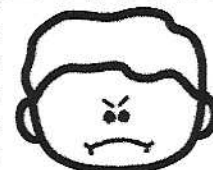

mad

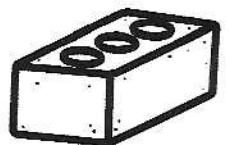

brick

Name:

Date:

Rhyming Pairs Cut & Paste #6

Cut and paste to match the rhyming pairs.

frog

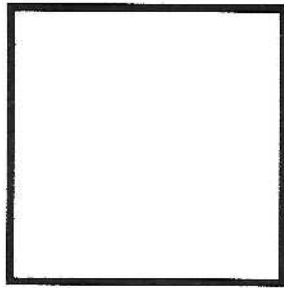
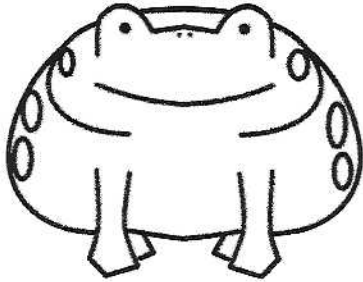

car

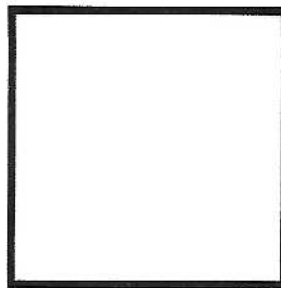
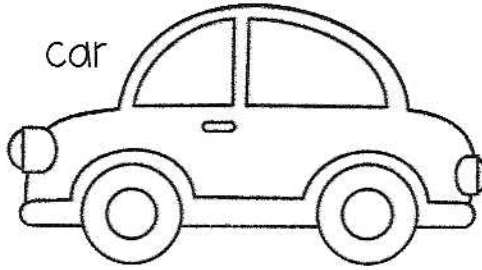

bug

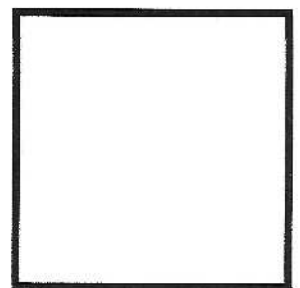
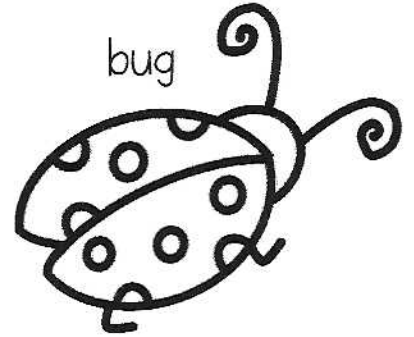

bell

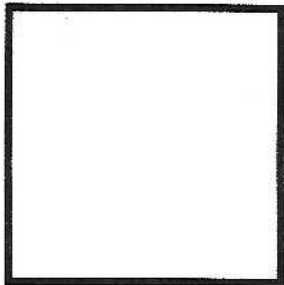
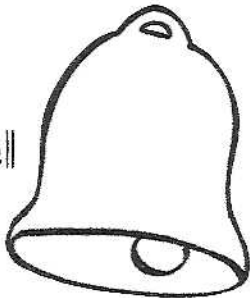

crab

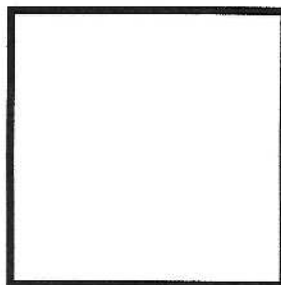
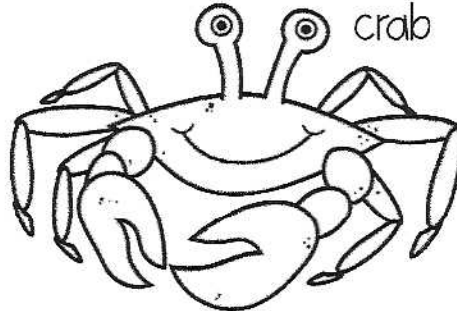

mat

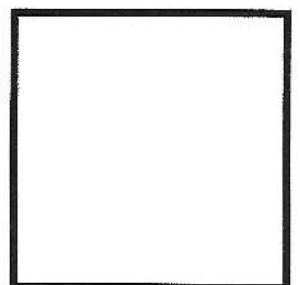

Rhyming Worksheets by Miss Vanessa



dog

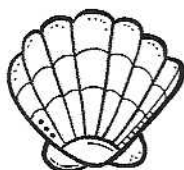

shell



jar



mug

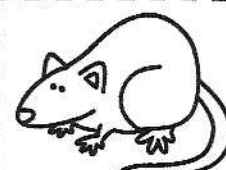

rat

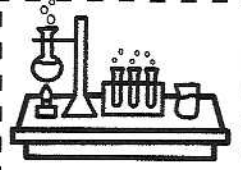

lab

Kindergarten

Math

Week 4





Class Activity

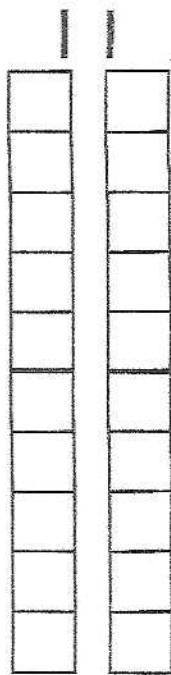

$$\begin{array}{r} 11 \\ \hline \end{array}$$

$$10 + \underline{\quad} = \underline{\quad}$$

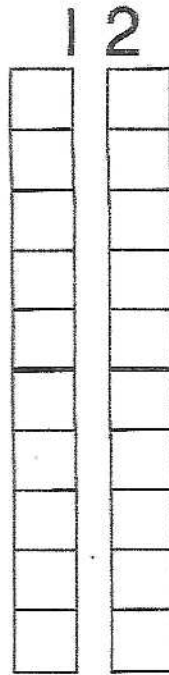

$$\begin{array}{r} 12 \\ \hline \end{array}$$

$$10 + \underline{\quad} = \underline{\quad}$$

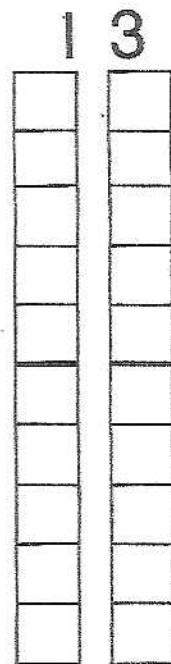

$$\begin{array}{r} 13 \\ \hline \end{array}$$

$$10 + \underline{\quad} = \underline{\quad}$$

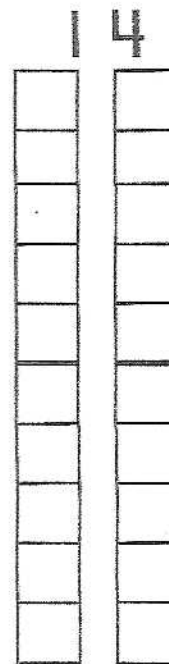

$$\begin{array}{r} 14 \\ \hline \end{array}$$

$$10 + \underline{\quad} = \underline{\quad}$$

1 5

15

$10 + \underline{\quad} = \underline{\quad}$

1 6

16

$10 + \underline{\quad} = \underline{\quad}$

1 7

17

$10 + \underline{\quad} = \underline{\quad}$

1 8

18

$10 + \underline{\quad} = \underline{\quad}$

Name _____

19

19

$$10 + \underline{\quad} = \underline{\quad}$$

20

20

$$10 + \underline{\quad} = \underline{\quad}$$

My

Unit 4

Teen Number

Book

By _____

Fold here.

1. Draw lines to match.

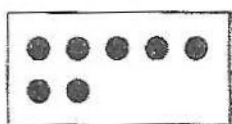

8

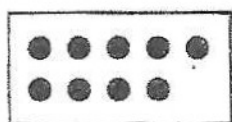

7

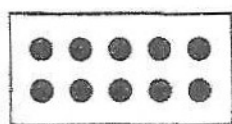

9

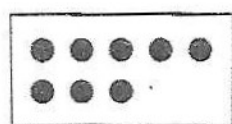

6

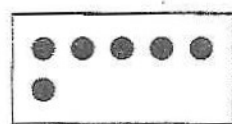

10



2. Make two matches.



2



1



3



4



5

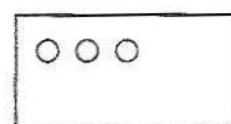
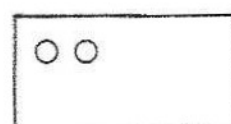
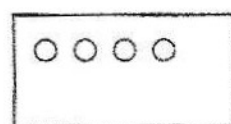
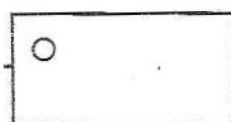
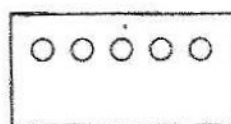

3. Count and write the number. Circle the number that is less.

2

4



Class Activity

PATH to
FLUENCY

4. Add the numbers.

$1 + 3 = \square$

$3 + 1 = \square$

$5 + 0 = \square$

$4 + 0 = \square$

$0 + 2 = \square$

$2 + 1 = \square$

$1 + 2 = \square$

$3 + 2 = \square$

$2 + 3 = \square$

$1 + 4 = \square$

$2 + 2 = \square$

$1 + 1 = \square$

$2 + 1 = \square$

$1 + 2 = \square$

$4 + 1 = \square$

$5 + 3 = \square$

$5 + 1 = \square$

$8 + 2 = \square$

$2 + 6 = \square$

$6 + 4 = \square$

$3 + 7 = \square$

$6 + 1 = \square$

$4 + 5 = \square$

$1 + 8 = \square$

$3 + 7 = \square$

$4 + 4 = \square$

$6 + 3 = \square$

**Class Activity**

1. Circle the objects shaped like cubes on the top shelf. Circle the objects shaped like cylinders on the middle shelf. Circle the objects shaped like spheres on the bottom shelf.

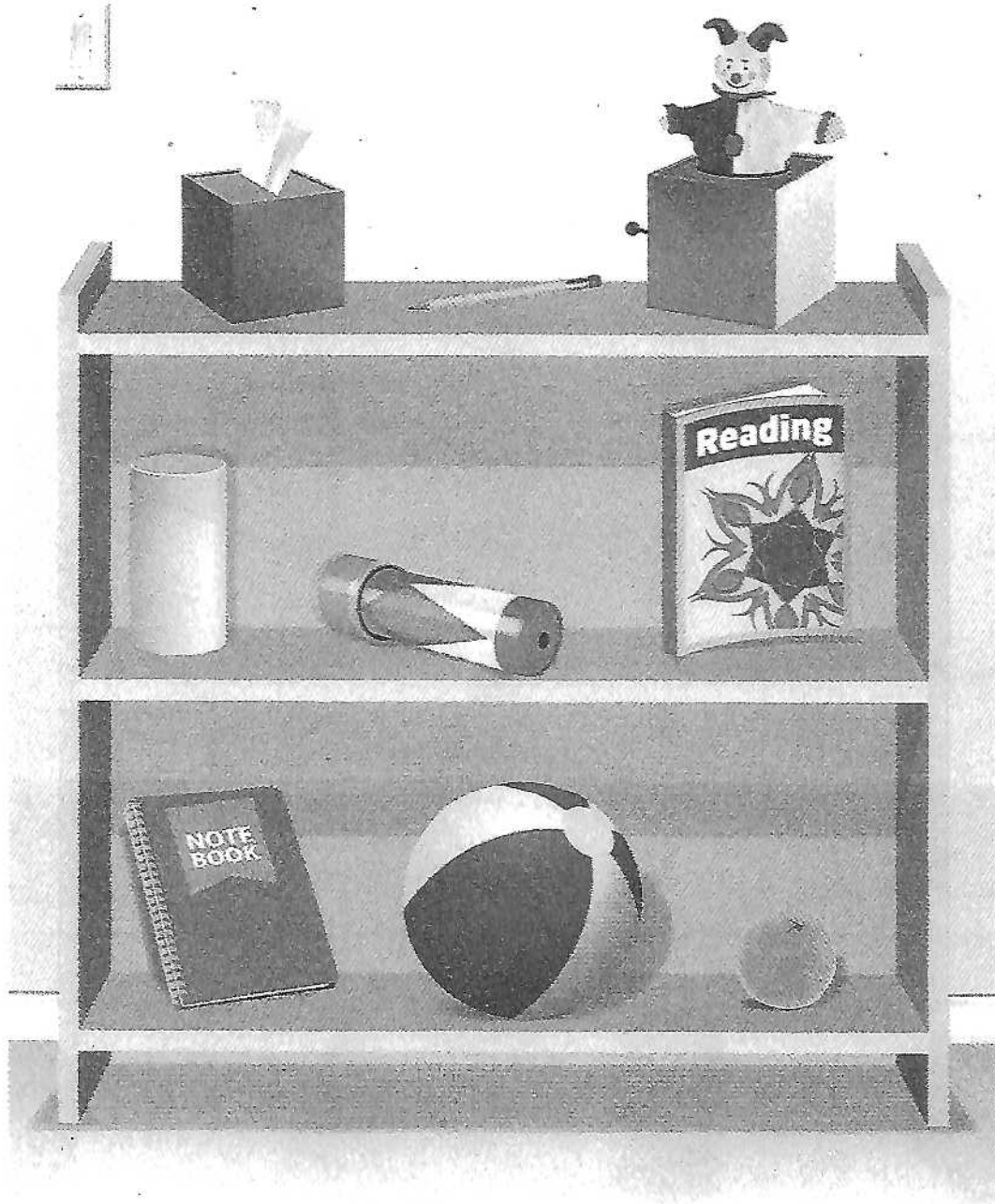



2. Color each kind of shape.

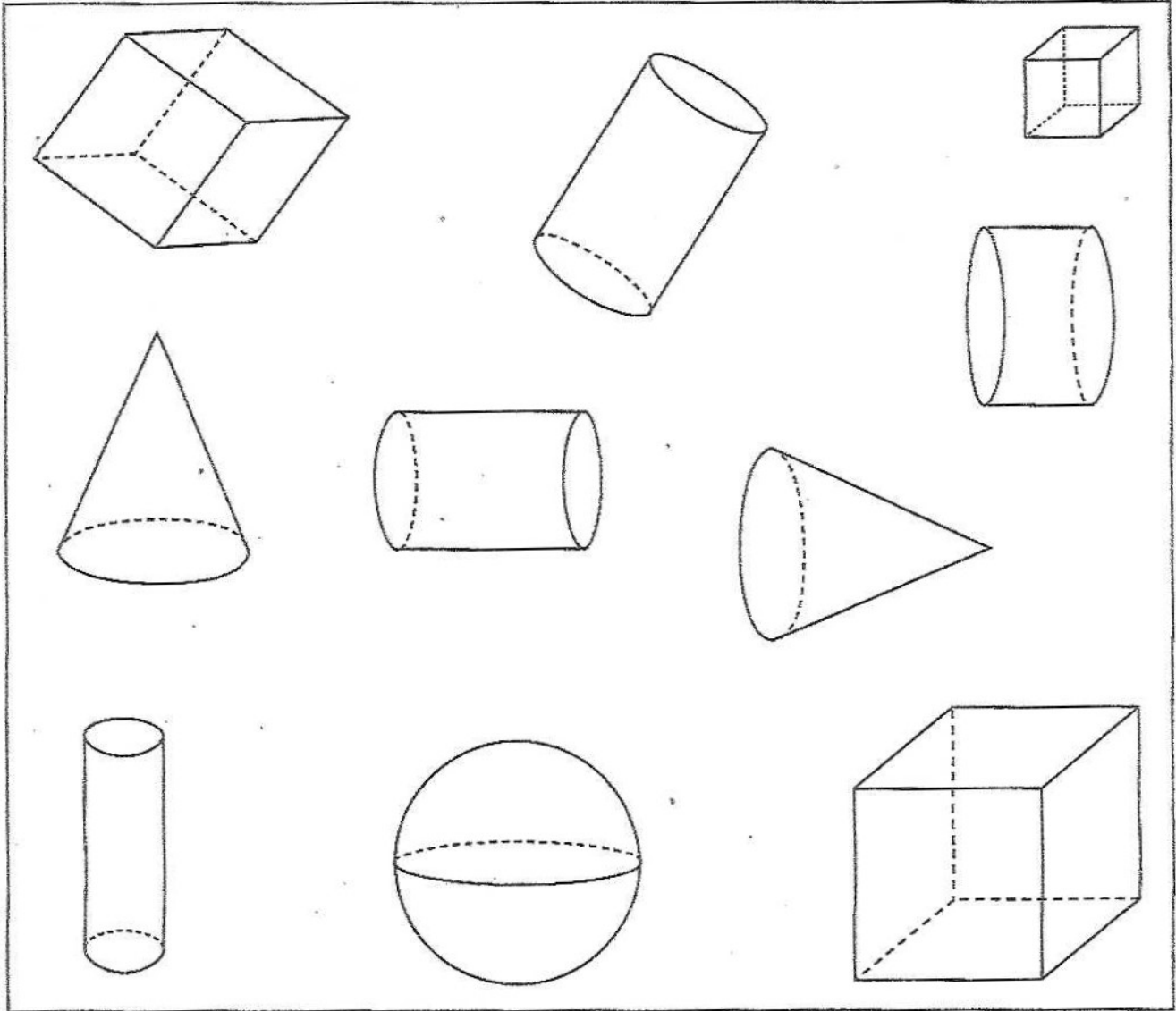

green



red



yellow

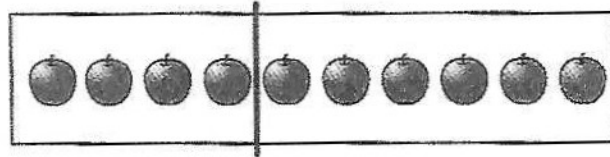
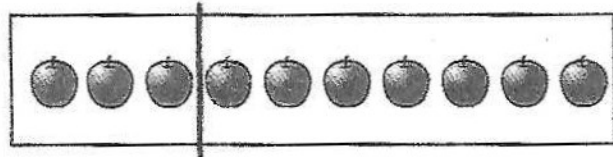

blue

**Exercises 1-2.** Write the partners.

$10 = \square + \square$

$10 = \square + \square$

Exercise 3. Draw.

The store has 9 apples. Dad buys 3 apples. Draw the apples the store has now.

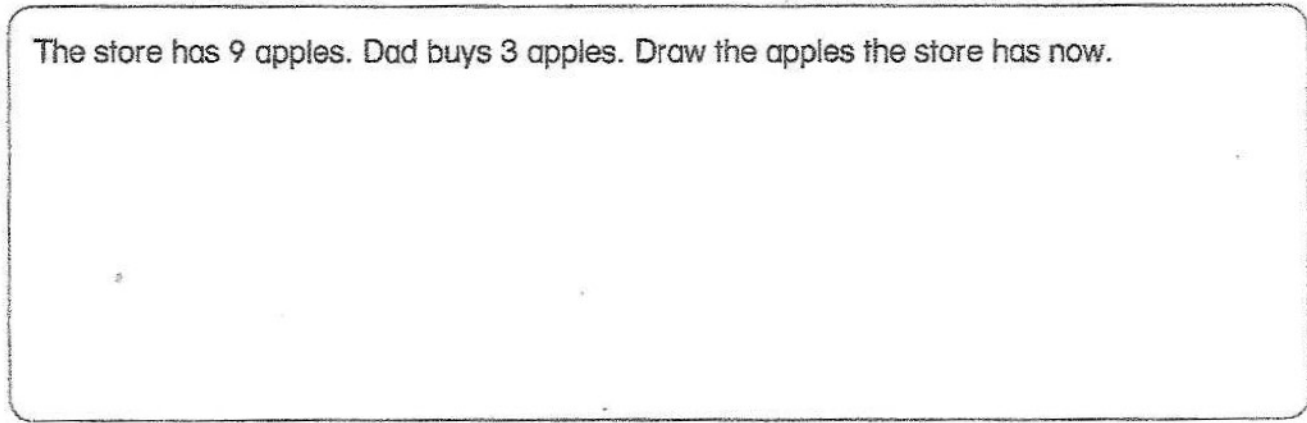
**Exercises 4-6.** Add the numbers.

$3 + 2 = \square$

$1 + 3 = \square$

$2 + 1 = \square$

Exercises 7-9. Subtract the numbers.

$4 - 3 = \square$

$5 - 0 = \square$

$3 - 1 = \square$



Exercises 10–11. Write the partners.

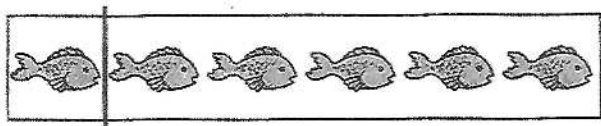

$$6 = \square + \square$$

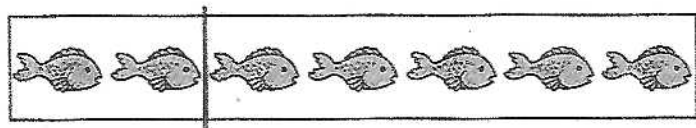

$$7 = \square + \square$$

Exercises 12–13. Count and write the number. Circle the number that is less.



Exercises 14–15. Complete the equation.

$$10 + 1 = \square$$

$$10 + 6 = \square$$



Exercises 16–17. Draw a line under the sphere. Circle the cone.



Exercise 18. Circle the cylinder that is next to the cube.



Exercise 19. Draw to show 15 as 10 ones and extra ones.



Exercises 20–21. Add the numbers.

$8 + 2 = \square$

$3 + 6 = \square$

Exercises 22–23. Subtract the numbers.

$9 - 1 = \square$

$7 - 4 = \square$

Exercise 24. Write the partner equation.

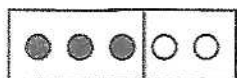

Exercise 25. Extended Response Draw a picture that shows partners for 7.
Write the partner equation.

Kindergarten

Reading

Week 4

Cut these pages apart and put together to make a collection of books to read. In addition to reading these books, your child can read other books at a level they are successful at, listen to and read along with stories read by you, and visit reading websites.

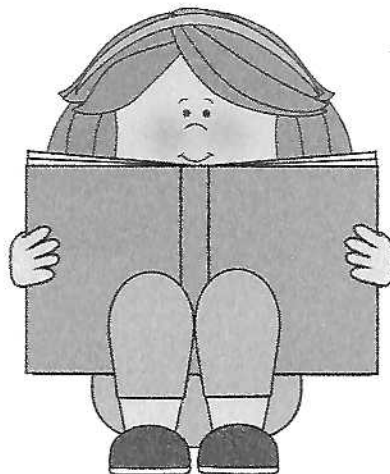

Practice writing the word **new**:

new new new

war
new

New Socks



A

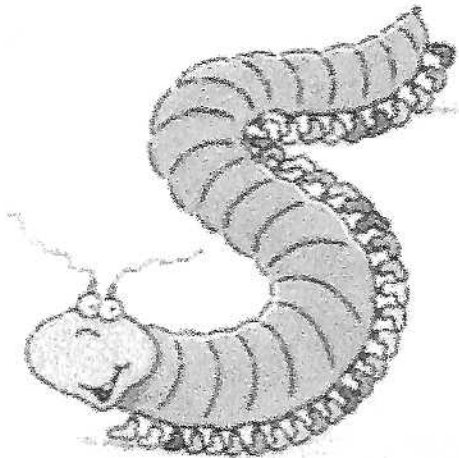

8 Lots of new socks. Wow!

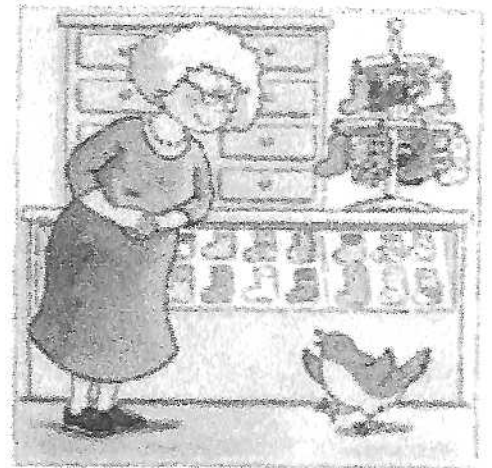

I want new socks.

1

B

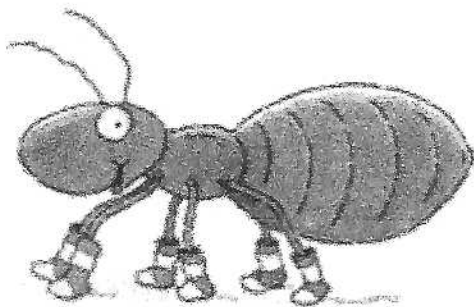

6 6 new socks.

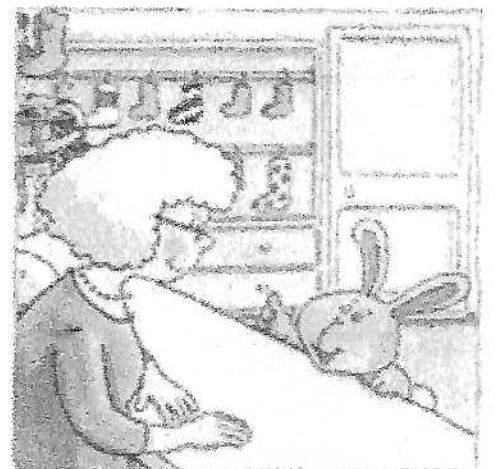

I want new socks.

3

C

Sue Wine Readers

Scholastic grants teachers permission to reprint this book for educational purposes.
Copyright © 2003 by Scholastic. All rights reserved.
Printed in the U.S.A.

Practice writing the word **want**:

want want

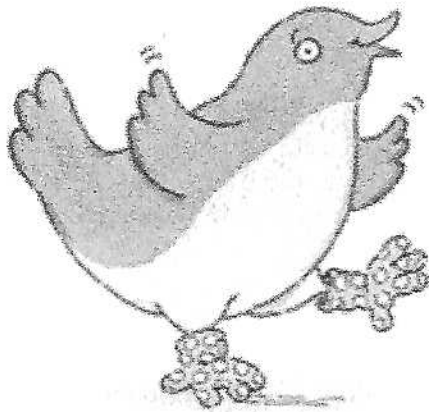

2

2 new socks.

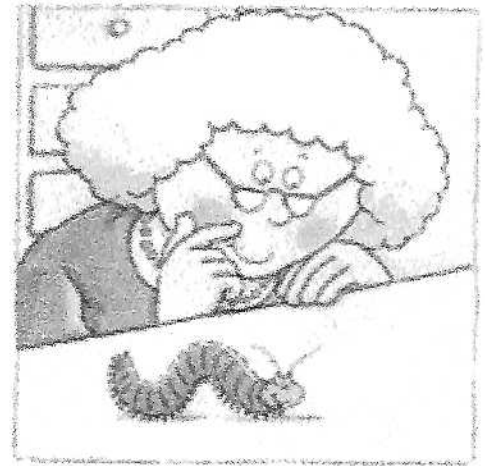

I want new socks.

7

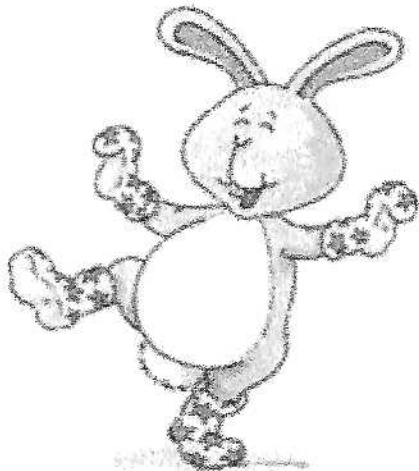

4

4 new socks.



I want new socks.

5

Practice writing the word **get**:

get get get

Sue Wen Readers

Dinner

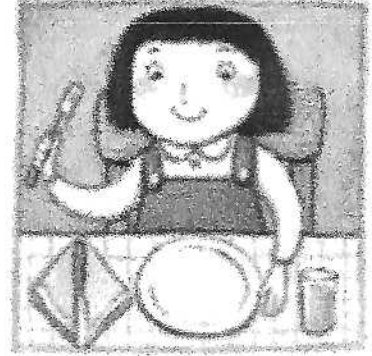

A



8

We get pizza!

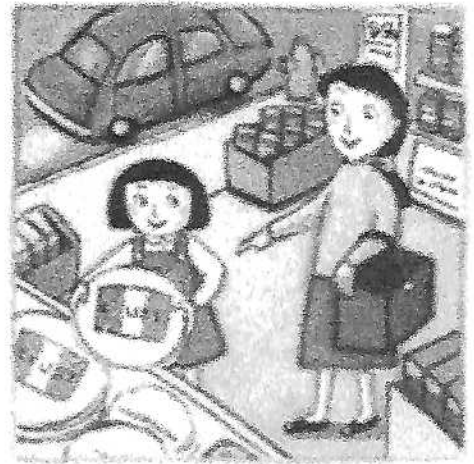

B

We get a crust.

1



6

We get spices.



C

We get tomatoes.

3

How We Read

Scholastic grants teachers permission to reprint this book for educational purposes.
Copyright © 2003 by Scholastic. All rights reserved.
Printed in the U.S.A.

Practice writing the word **We**:

we we we we



2

We get cheese.



7

We get pepperoni.



4

We get onions.

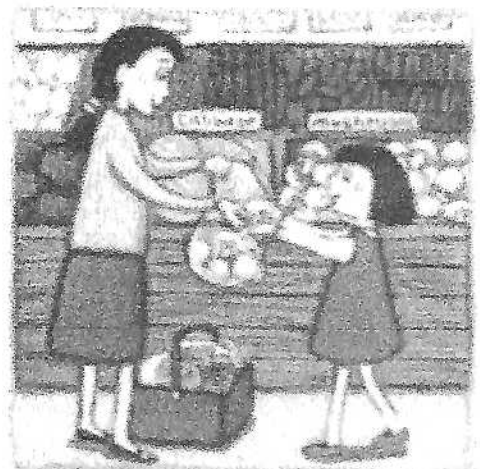

5

We get mushrooms.

Practice writing the word are:

are are are

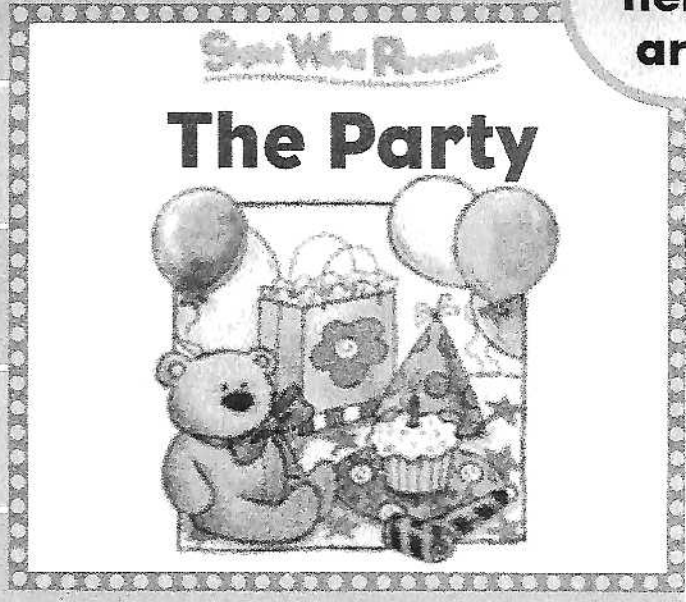

A



8

Surprise!

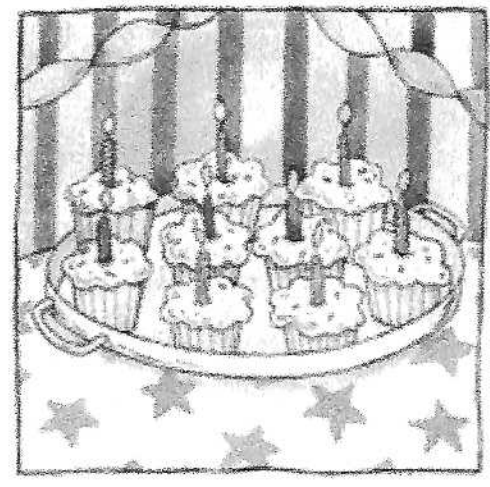

1

B

Here are the cupcakes.



6

Here are the gifts.

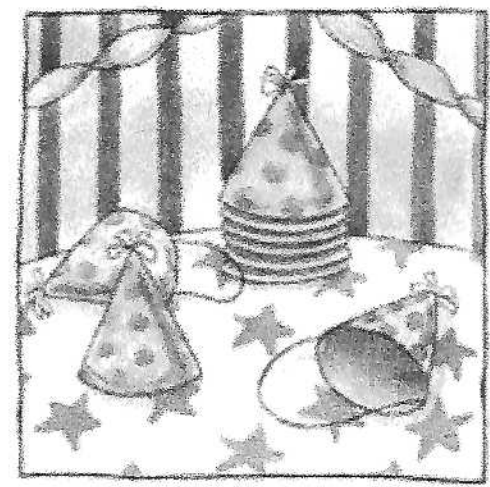

3

C

Here are the hats.

Good and Beautiful

Scholastic grants teachers permission to reprint this book for educational purposes.
Copyright © 2003 by Scholastic. All rights reserved.
Printed in the U.S.A.

Practice writing the word **here**:

here here

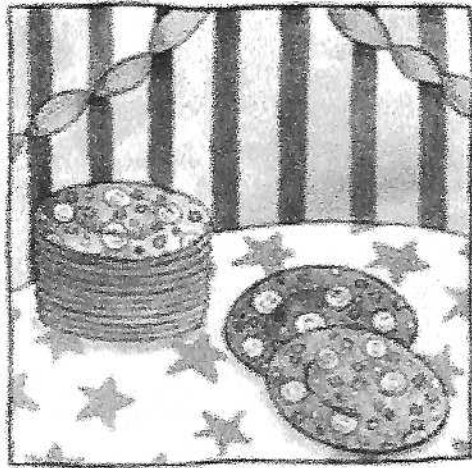

2 Here are the plates.

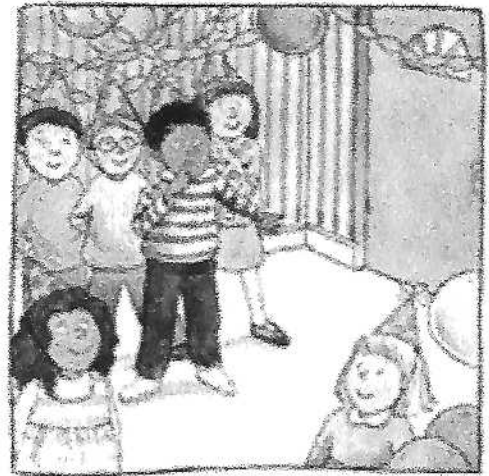

7 Here are the guests.

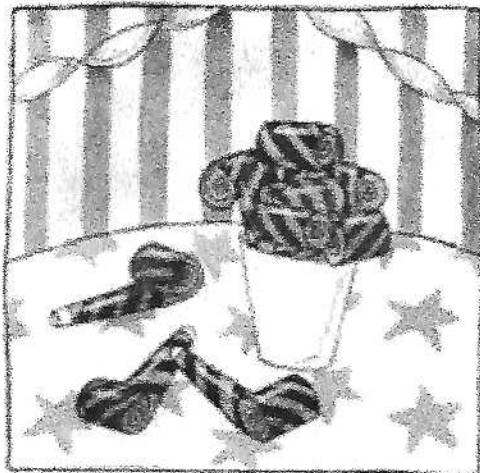

4 Here are the horns.

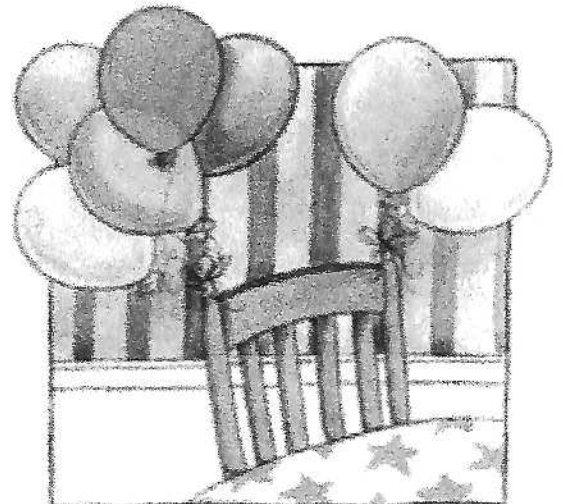

5 Here are the balloons.

Practice writing the word **on**:

on on on on

rid
or

Sight Word Readers

Ride On!



A



8

Ride on a float! 



B

Ride on a bus. 

1



6

Ride on a boat. 



C

Ride on a bike. 

3

See What Readers

Scholastic grants teachers permission to reprint this book for educational purposes.
Copyright © 2003 by Scholastic. All rights reserved.
Printed in the U.S.A.

Practice writing the word ride:

ride ride ride



2

Ride on a plane. 



Ride on a sled.  7



4

Ride on a train. 



Ride on a horse.  5

Practice writing the word funny:

funny funny

Sight Word Readers

a
funny

That Is Funny!

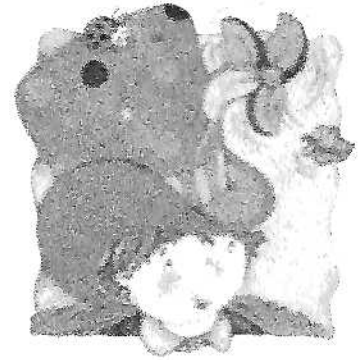

A



8

And funny us!

B

A funny bike.

1



6

A funny bus.

C

A funny man.

3

Practice writing the word **a**:



2

A funny cat.

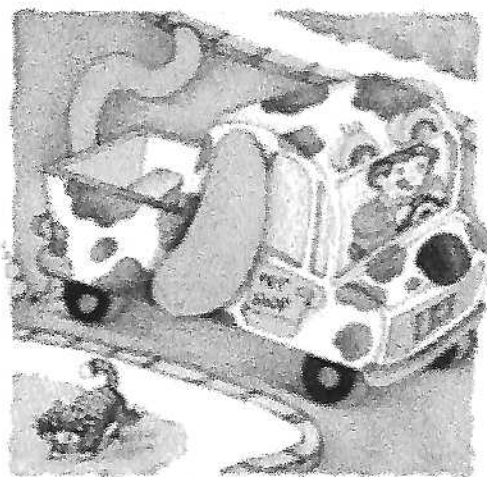

A funny truck.

7

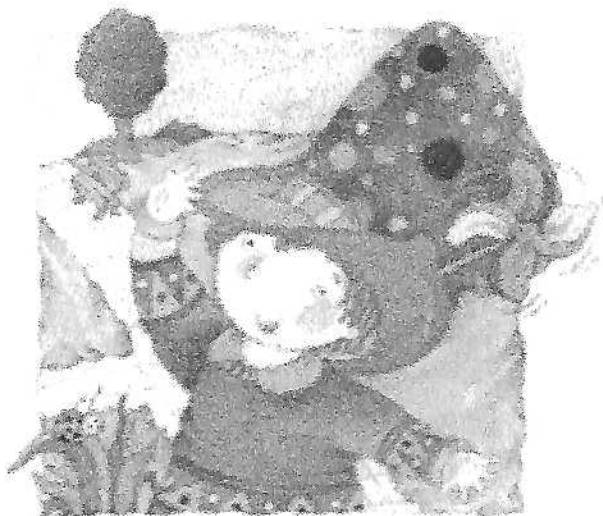

4

A funny hat.

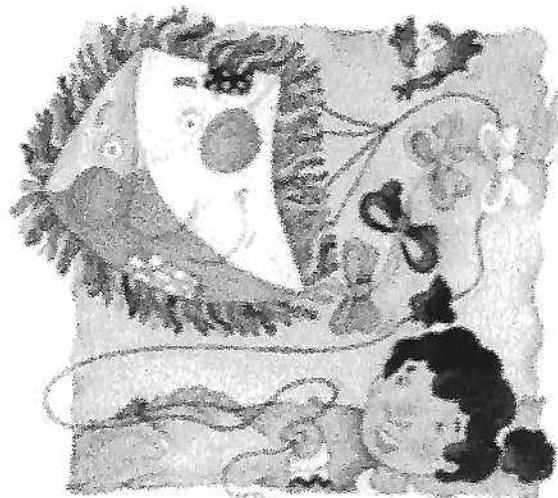

A funny kite.

5

Practice writing the word too:

too too too

m
to

Sun View Readers

Me Too!



A

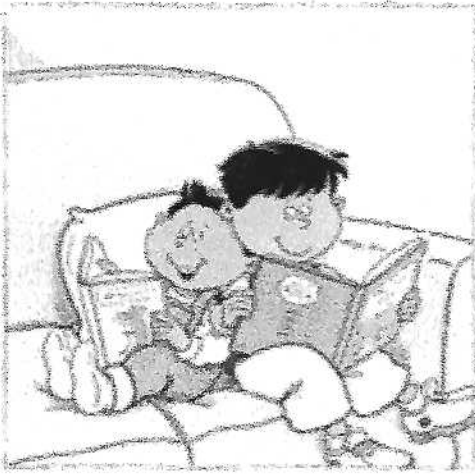

8

Me too!



1

B

I ride.



6

Me too.

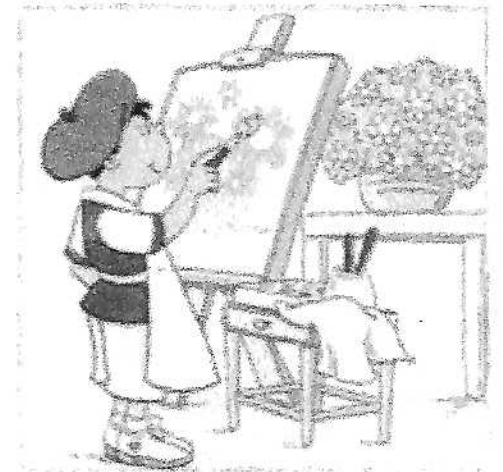

3

C

I paint.

Star Wars Presents

Scholastic grants teachers permission to reprint this book for educational purposes.
Copyright © 2003 by Scholastic. All rights reserved.
Printed in the U.S.A.

Practice writing the word **me**:

me me me



2

Me too.

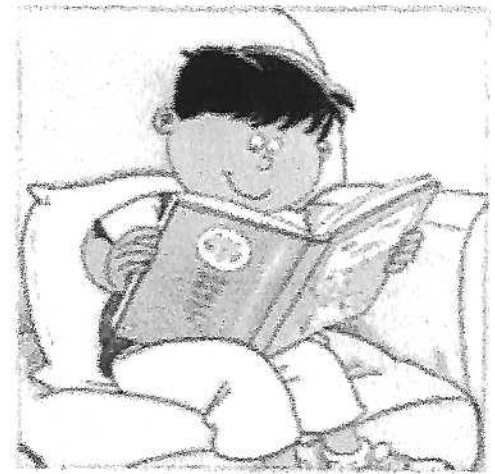

7

I read.

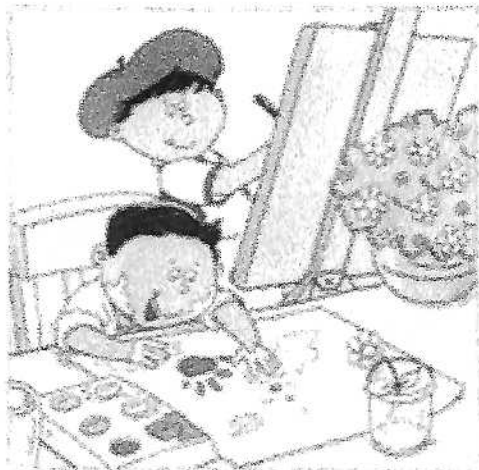

4

Me too.

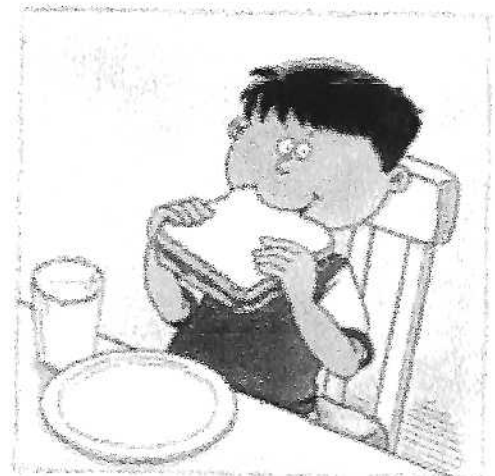

5

I eat.

Kindergarten



Writing Week 4

Small Moment Writing –

This type of writing is similar to journal writing. Your child should write about something they have done before. At school I encourage them to tell when it was, where they are, who is with them, and how they felt. Along with their writing they should draw a picture.

Opinion Letter –

Write a letter to someone to tell their opinion of something. I encourage them to include an introduction, their opinion, why they feel that way, and to ask something else. I also encourage strong the use of strong feelings other than “like” and “not like.” For example:

Dear Mrs. Bennett,

I watched Frozen 2 the other night. I loved it because I really loved the songs and Elsa’s new dress. Have you seen Frozen 2 yet?

From,
Grace

Informational –

Your child should be able to write a minimum of 3 facts about something. It can be anything they know at least 3 facts about; dogs, cats, a person in their family, a food, a season, or just about anything.

In all forms of writing, emphasize capital letters just at the beginning of sentences and in proper nouns, appropriate punctuation at the end of sentences, and phonetic spelling. Your child may ask you to how to spell a word, but instead of telling the, ask them what sounds they hear. At school, we grab the word out of the air with our hand and let it out slowly. For example, if they want to spell puzzle, they would hear p-u-z-l. They may write is puzl, but they wrote a letter for each sound they heard

a b c d e f g h i j k l m n o p q r s t u v w x y z

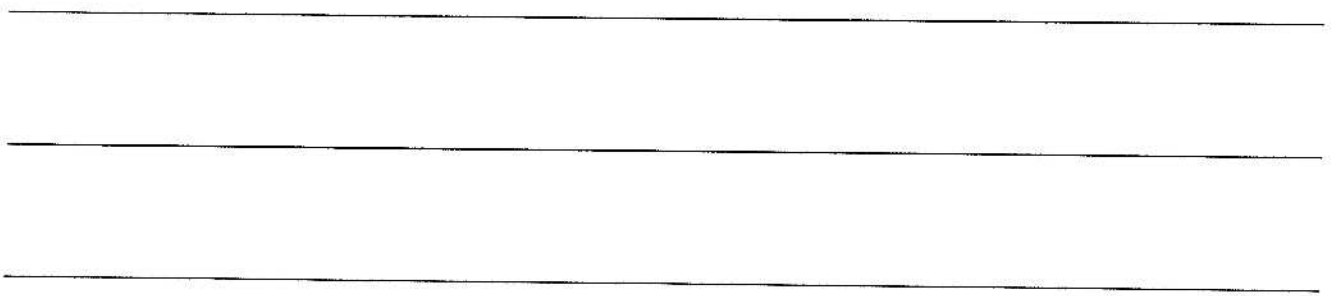
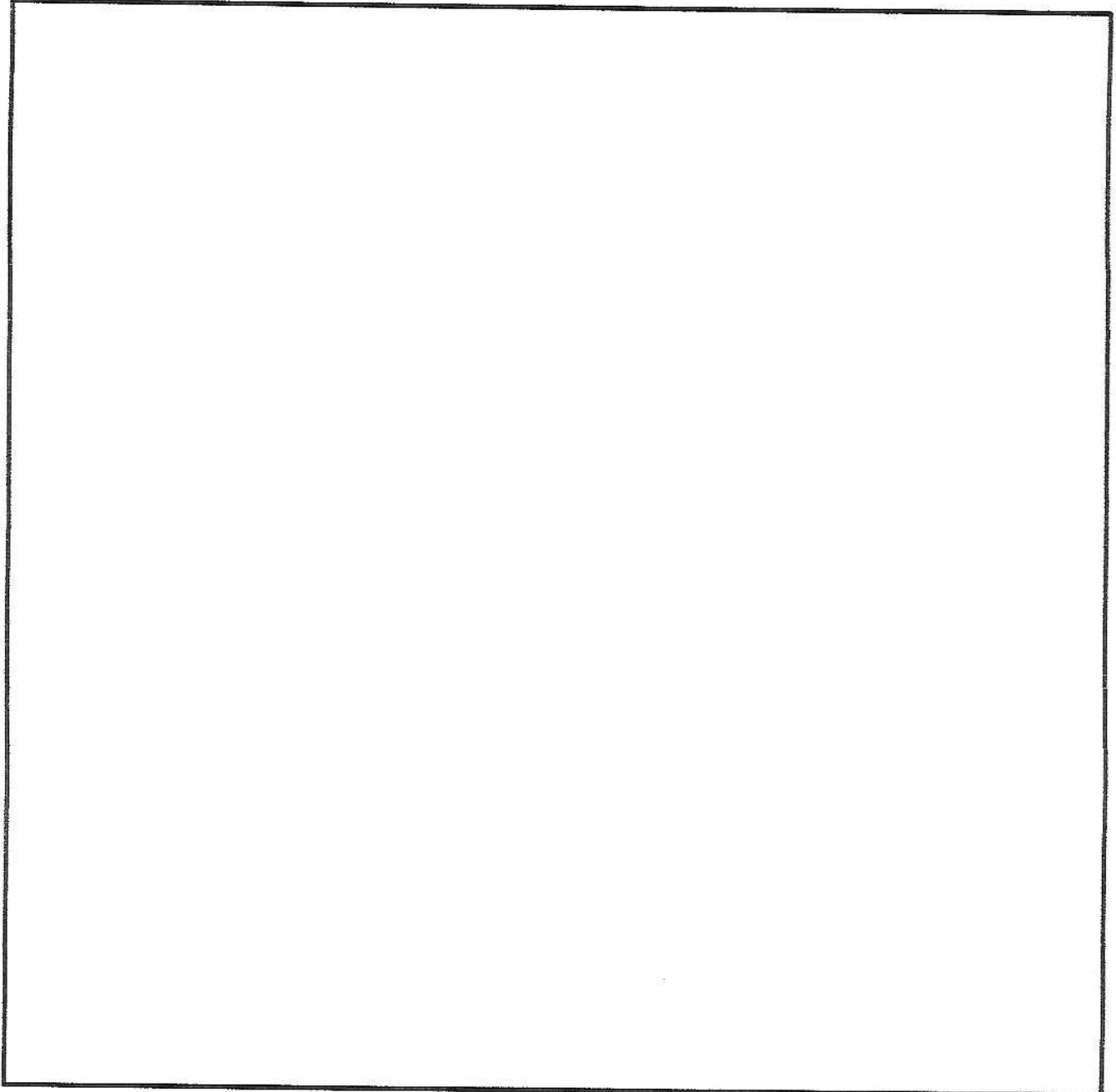

a b c d e f g h i j k l m n o p q r s t u v w x y z

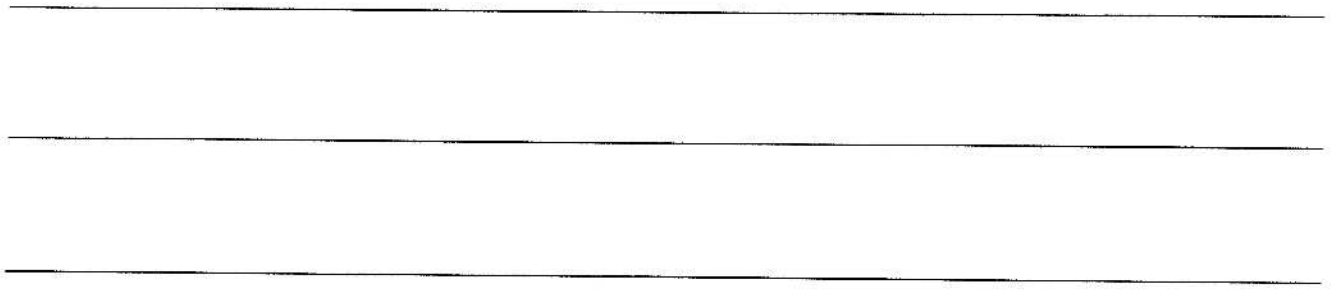
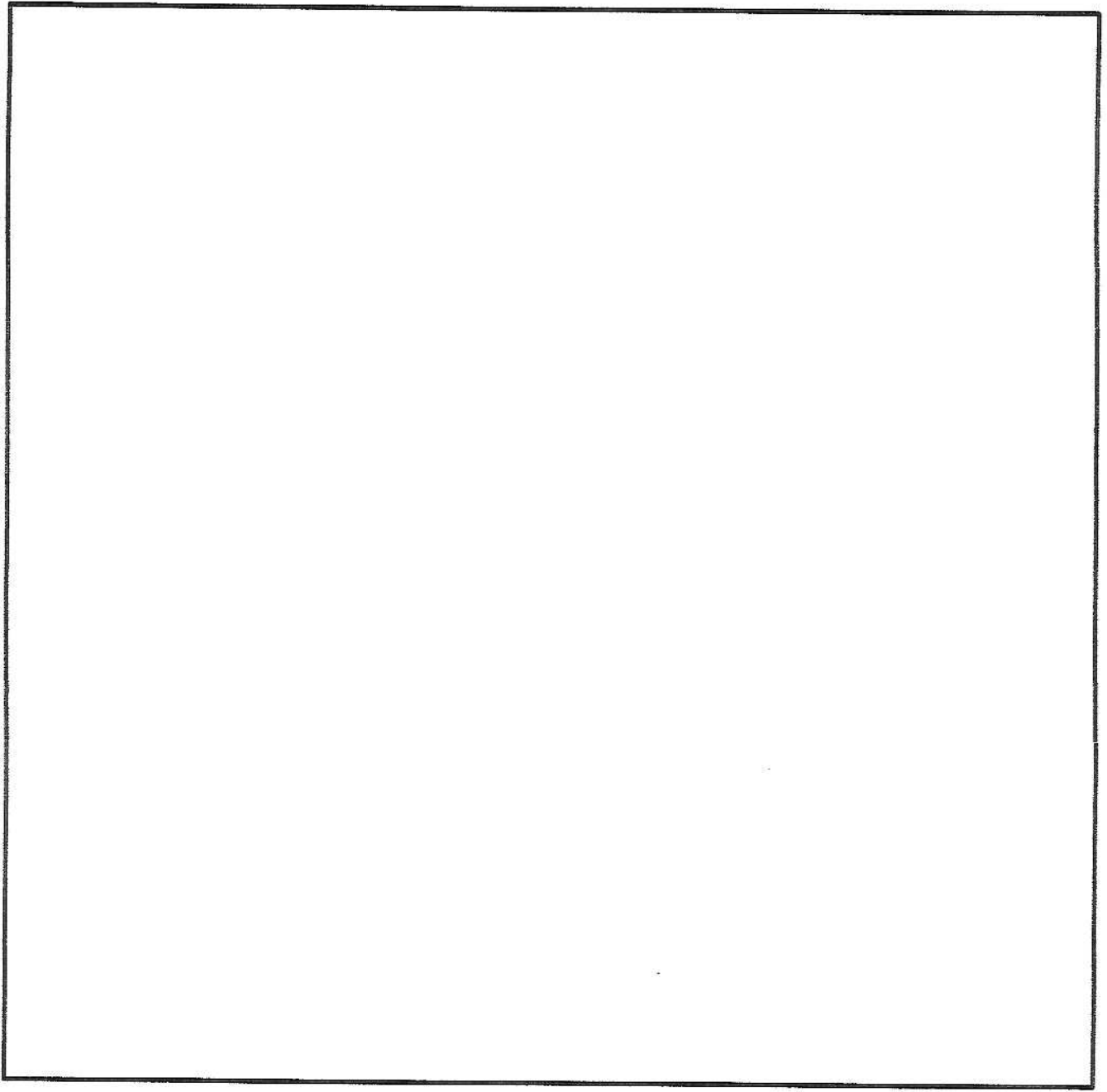

a b c d e f g h i j k l m n o p q r s t u v w x y z

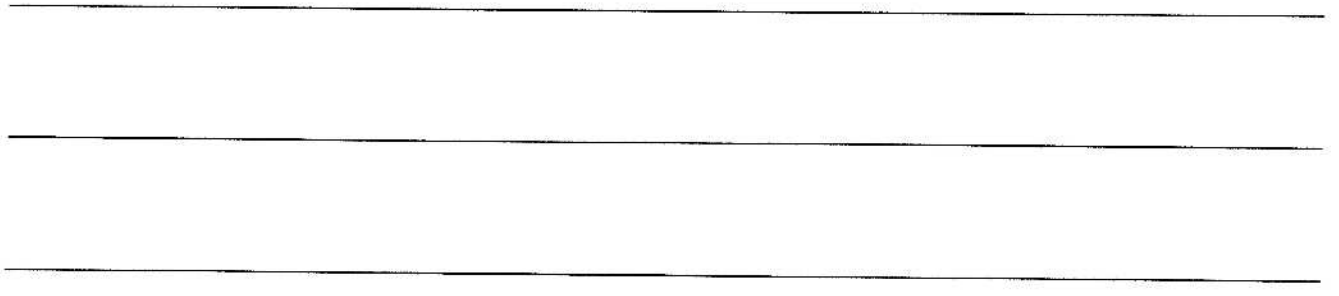
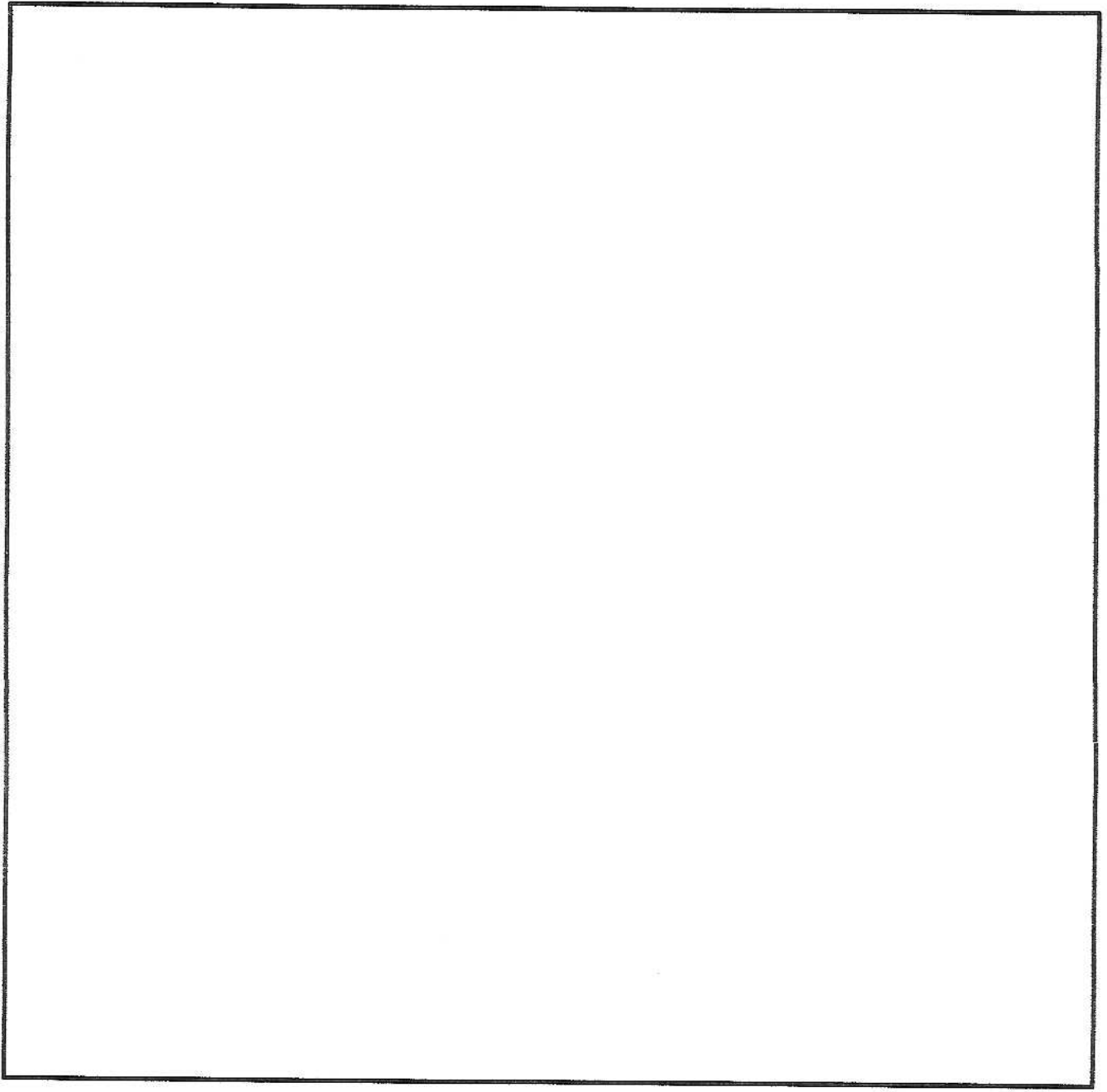

a b c d e f g h i j k l m n o p q r s t u v w x y z

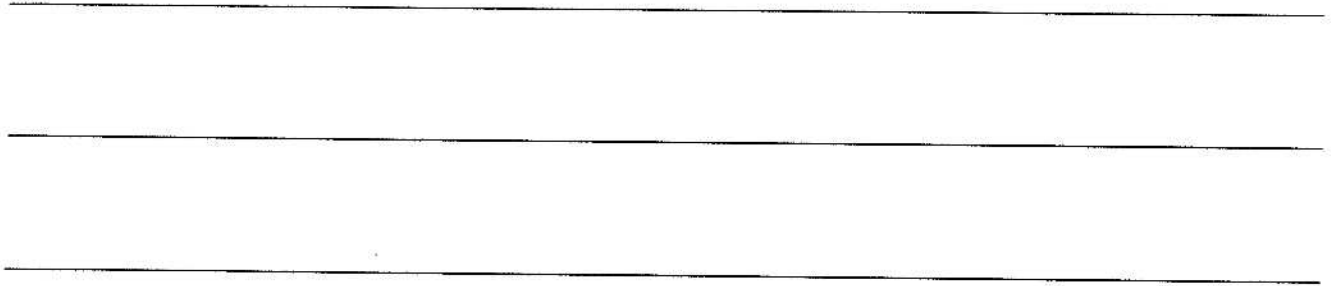
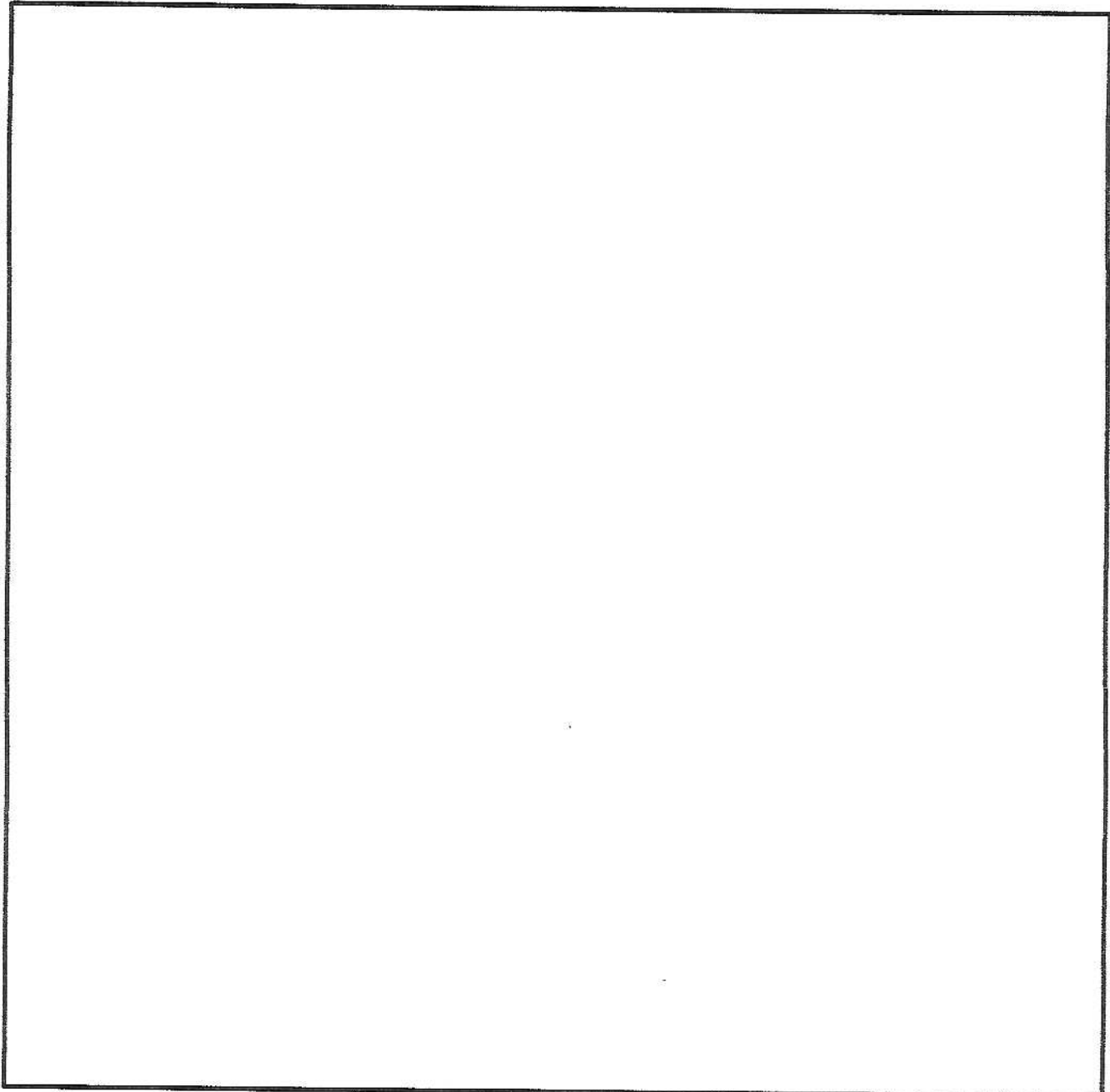

a b c d e f g h i j k l m n o p q r s t u v w x y z

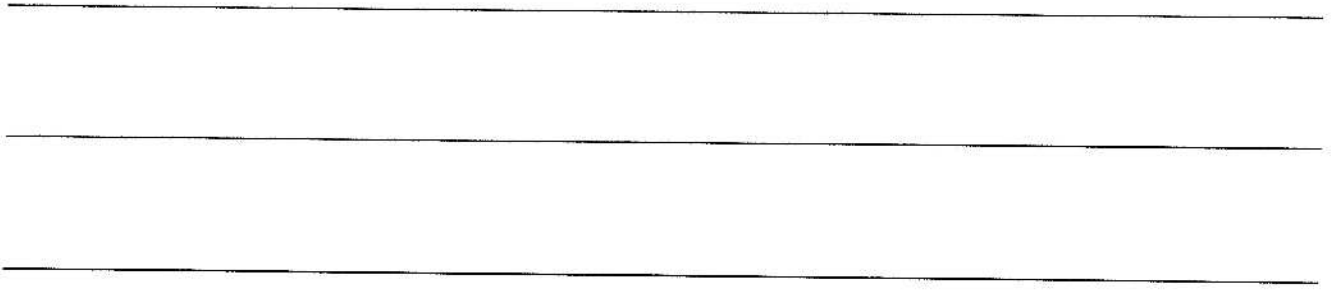
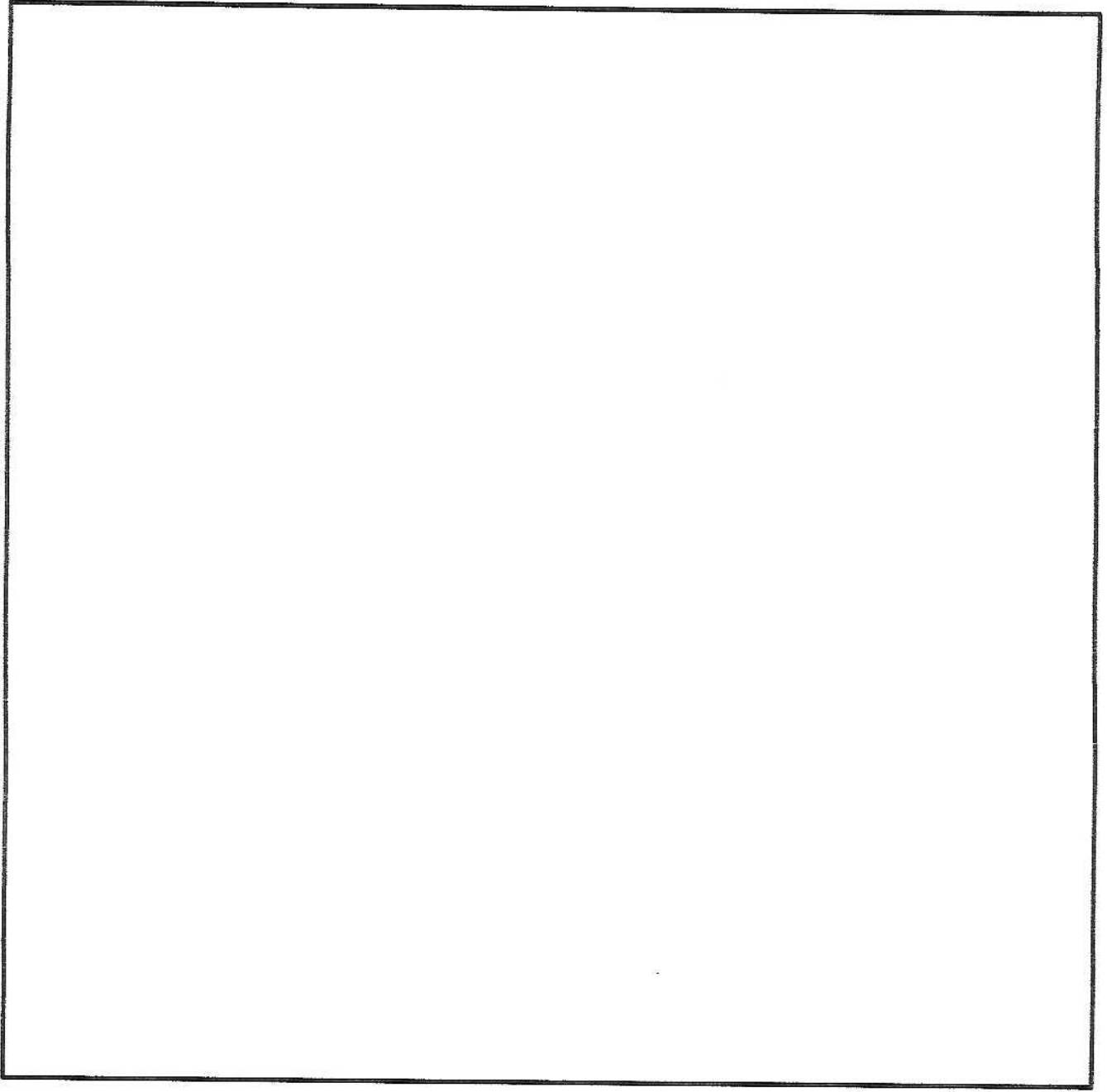

a b c d e f g h i j k l m n o p q r s t u v w x y z

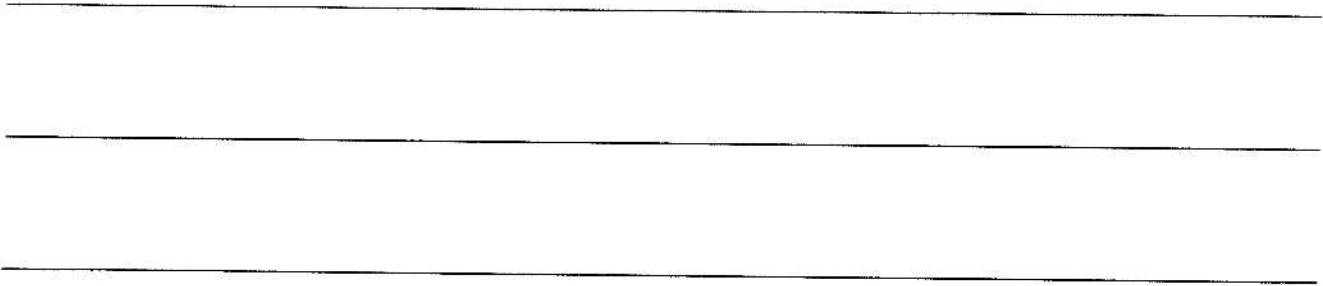
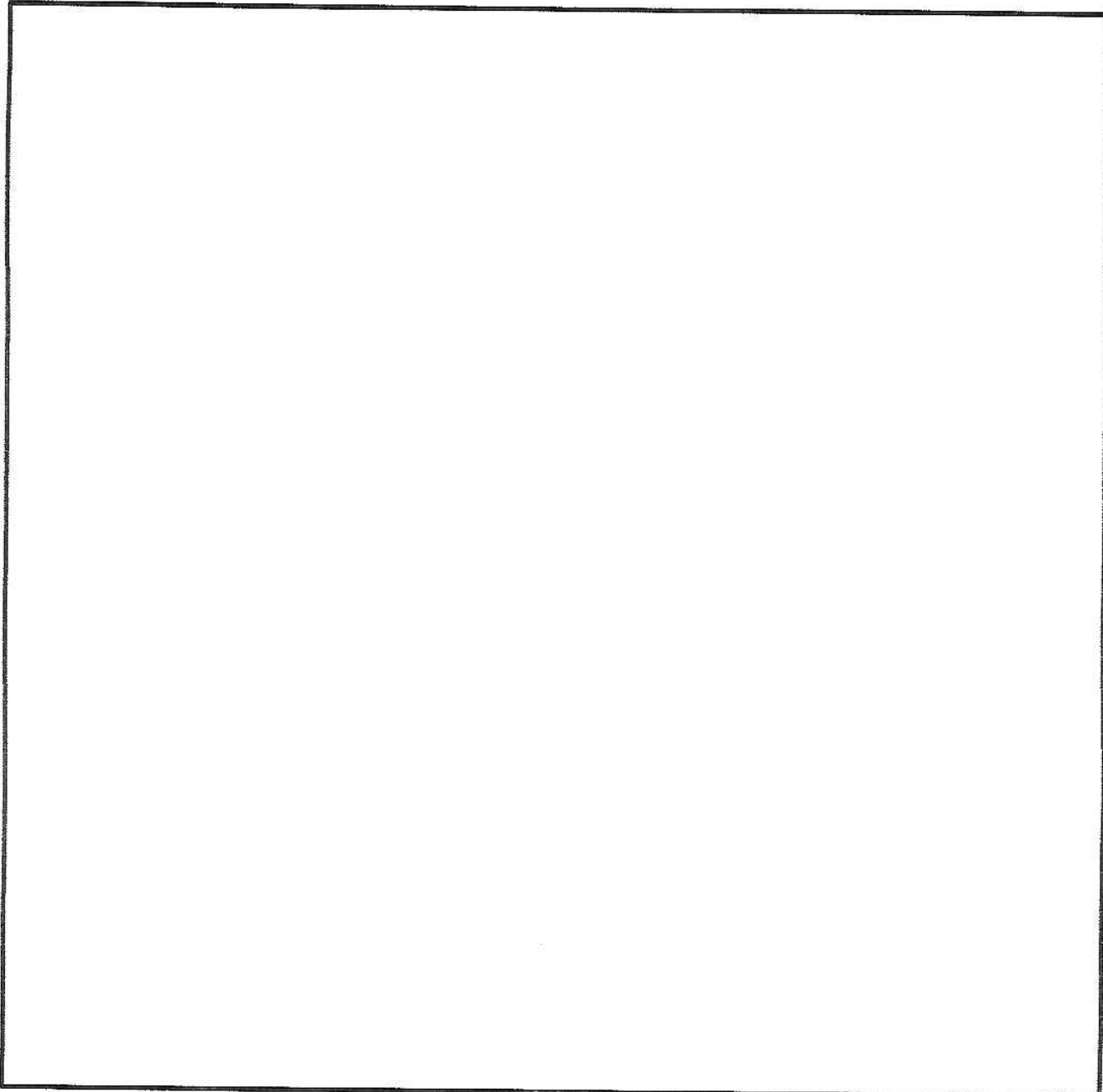

1.

2.

3.

A large, empty rectangular box with a thin black border, occupying the lower half of the page. It is intended for the student to write their response to the prompts.

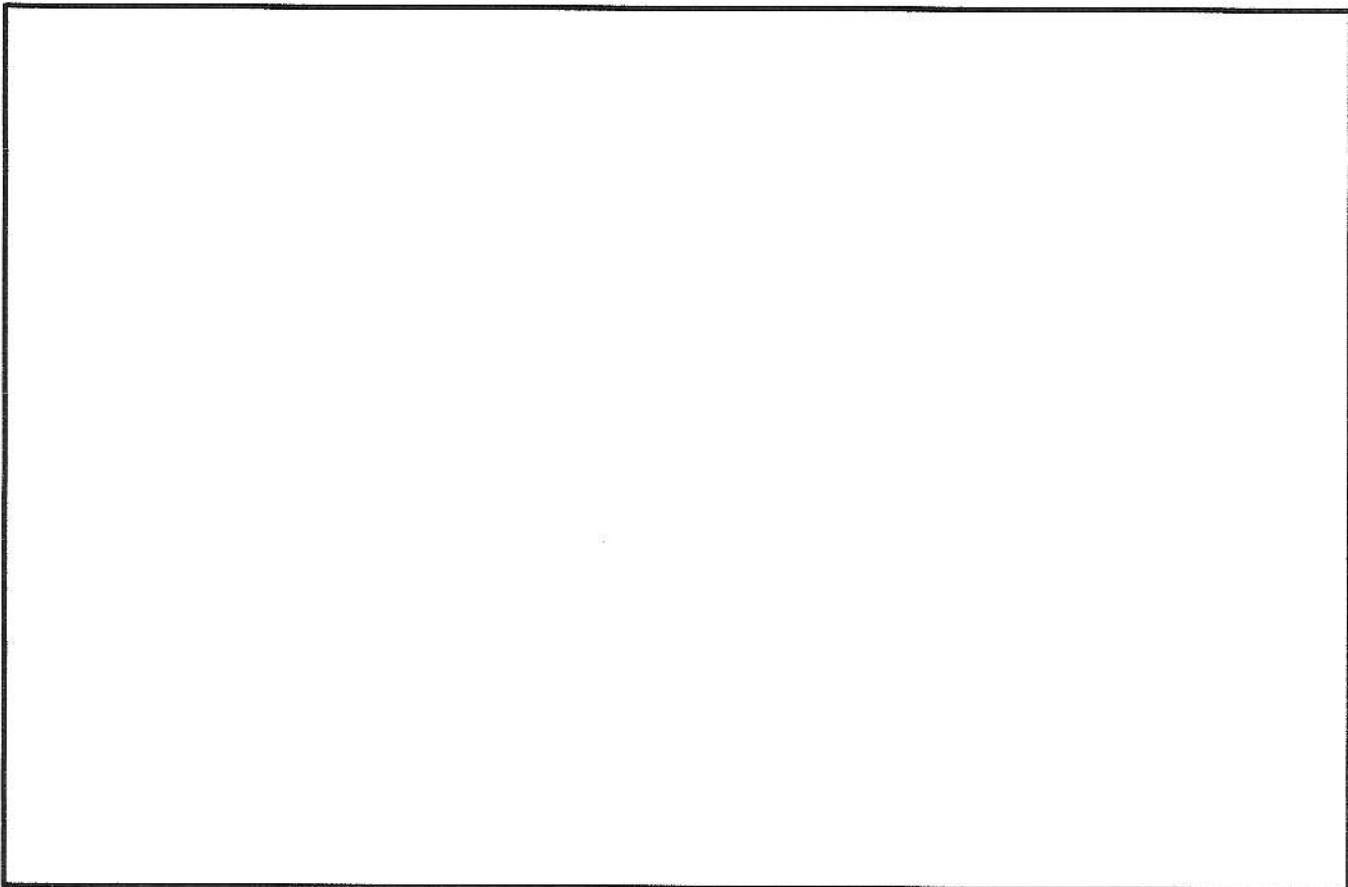

1.

2.

3.
